

A company dedicated to solving ergonomic and material handling problems since 1955.

OWNER'S MANUAL

SEMI-AUTOMATIC STRETCH WRAP MACHINE MODEL SWA-48, POW-CAR

Contents

Installation Instructions	2-3	SWA-48, POW-CAR Electrical Diagram	10
Routine Maintenance & Safety Chocks	4	Powered Mast Electrical Diagram	11
Belt Tensioning Procedure	5	Motor Speed Controller Parameters	13
Operation Instructions	6	Troubleshooting	13
Exploded Turntable Parts Drawing & BOM	7	Safety Label Identification	14
Exploded Mast Parts Drawing & BOM	8-9	Warranty	15

WARNINGS & SAFETY INSTRUCTIONS

Ensure that all employees understand and follow the following.

- Read and understand the owner's manual before using or servicing the stretch-wrap machine.
- Ensure that all safety and warning labels stay in place and that they are legible.
- Do not use the machine if any damage or unusual noise is observed.
- Watch the pallet or container carefully when the turntable is in motion, particularly in the case of any overhanging load.
- Rotating the palletized loads can become unstable. Be prepared to stop the turntable in the event the load shifts.
- Make certain that the load is centered and stable before operating the turntable.
- Warning: Keep all personnel clear of the machine when it is in operation. Be certain no part of any person, fork truck, or other object is in the path of the rotating load before rotating the turntable.
- Warning: Do not stand or sit on the turntable or its load at any time.
- Warning: Keep all body parts and clothing away from the machine's drive system(s).
- Do not perform any modifications to the stretch-wrap machine or its mast without the manufacturer's approval. Failure to receive authorization for changes to the equipment could void the warranty.
- Maintenance and repairs are to be done only by personnel qualified to perform the required work. Consideration will not be given for warranty repair labor charges without prior written authorization by the manufacturer.

damage or rough handling to either the packaging or to the product when it is being unloaded, immediately make a note of it on the Bill of Lading!

It is important that you remove the product's packing upon its arrival to ensure that there is no concealed damage or to enable a timely claim with the carrier for freight damage.

Also, verify that the product and its specifications are as ordered.

WHEN ORDERING REPLACEMENT PARTS

We take pride in using quality parts on the equipment we manufacture. We are not responsible for equipment problems resulting from the use of unapproved replacement parts. To order replacement or spare parts for this equipment, contact the manufacturer.

In any communication with the manufacturer, please be prepared to provide the machine's serial number, which is indication of the machine dataplate.

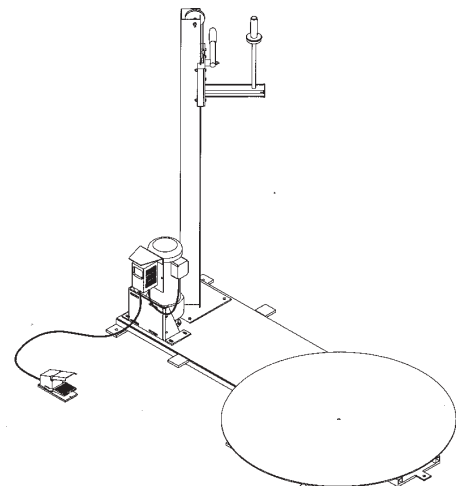

**SEMI-AUTOMATIC STRETCH WRAP MACHINE
 MODEL SWA-48, POW-CAR**

RECEIVING INSTRUCTIONS

Every unit is thoroughly tested and inspected prior to shipment. However, it is possible that the unit may incur damage during transit. Inspect the unit closely when it arrives. If you see evidence of

INSTALLATION INSTRUCTIONS – SWA-48, POW-CAR

Review this entire instruction set before installing the stretch-wrap machine.

Consult the manufacturer in the event there are any questions or problems at the time of installation, or for information regarding optional features not covered by the owner's manual.

The model SWA-48 stretch-wrap machine must be removed from the shipping wood and securely anchored to the floor before use!

- Modifications or the addition of ancillary equipment to any part of the stretch-wrap machine without prior manufacturer's authorization may void the machine's warranty.
- The installation should be made so that it complies with all regulations applicable to the machine and its location. The end-user must verify that the supplied equipment is installed so it will be suited to the environment in which it will be used.
- Installation must be performed by suitably trained personnel with access to the appropriate equipment. The electrical aspects of the installation should be performed by an electrician.
- Choose a location for the machine that will be free of obstructions to the largest diameter load that could be placed on the turntable. Consideration should also be given to the approach path(s) of pallet trucks and fork trucks so that personnel, the motor speed control, and the foot switch and its cord can be adequately protected from injury or damage.

For a typical installation, you will need the following:

- i. A fork truck or hoisting means to unload the machine from the freight truck and to set it into place.
- ii. A smooth, level, and adequately strong concrete surface on which to mount the machine's frame.
- iii. Concrete anchors, a masonry drill, a masonry bit, hand tools, grout, and steel shims. Consult the building's architect or facility engineer to determine the best size and type of hardware with which to anchor the machine to the floor.
- iv. A power supply circuit and disconnect matching the motor voltage and current requirements. Refer to the machine's dataplate, to the labels on the control enclosure, and to the electrical section in this manual, for more information. The end-user is responsible for supplying the branch circuit's required (by code) overcurrent and short-circuit protection.

Note: Static electricity is produced on the stretch-wrap film as it pulls off the roll during the stretch-wrapping of a palletized load. The static effect might intensify in dry air. If undesirable affects of static on personnel or product are experienced, consult an ESD (electrostatic discharge) product supplier for available methods to dissipate static.

MACHINE INSTALLATION

1. Move the machine to its installation location by inserting the forks of a fork lift along each side of the frame until the fork tips are under the ½" x 3" x 3" tabs on each side. Use care to avoid damaging the electrical components and cable.
2. Prop up the motor end of the frame on a wooden 4 x 4 (or similar).
3. Stand the stretch-wrap mast upright on the end of the machine's frame so that the material carriage arm projects over the side of the frame. Align the hole in each corner of the mast mounting plate with its corresponding hole in the machine's frame.
4. Bolt the stretch-wrap mast to the machine's frame with the hardware provided, and wrench-tighten.
5. Remove the counterbalance retaining screw located approximately 12" up from the mast's base plate, and cut the cable tie holding the mast cable to the pulley at the top of the mast.
6. Anchor the machine's frame to the floor through the 9/16" holes located at the frame corners and at the end of the frame, under the edge of the turntable. Tighten the anchors only to the point where the frame is level.
7. Shim and/or grout under the frame sides as necessary to prevent bowing of the frame.
8. Tighten all of the floor anchors wrench-tight.
9. Bolt the motor/drive assembly onto the gear reducer using the included hardware and shaft key. When finished, the electronic drive should be facing outward over the side of the machine's frame.
10. Insert the turntable's power cord plug into a standard 15A or 20A, 115 VAC receptacle. If a powered mast is installed onto the machine, the turntable's power cord can plug into the pigtail coming out of the mast's control enclosure, and the mast's power cord can then be plugged into a 115V receptacle to supply both parts of the machine.
11. Verify that the turntable rotates and that the speed control knob provides full speed range adjustment.
12. If a powered mast is installed, verify that the mast operates and that the mast's upper and lower travel limit switches function properly.
13. Clean up any debris, and verify that all the warning and safety labels are intact.

MATERIAL HOLDER ASSEMBLY

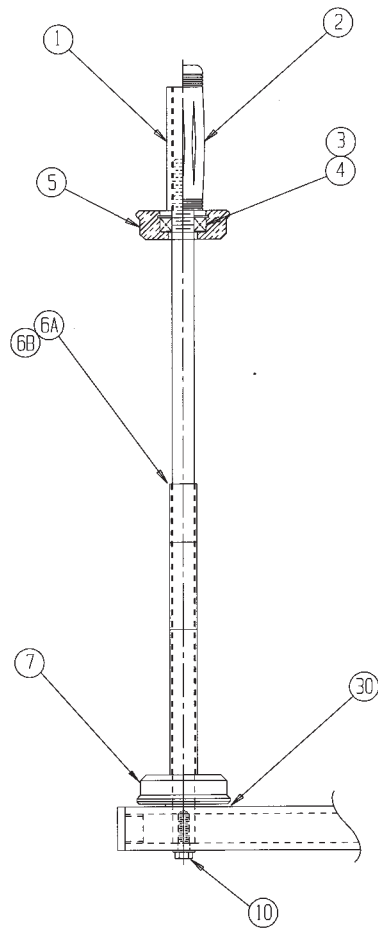

14. Unscrew and remove the plastic tension grip handle from the top of the stretch-wrap material holder rod.
15. Remove the top plastic stretch-wrap material tube retainer (it should have a bearing pressed into it) from the material holder rod.
16. Remove from the material rod any spacer tubes that will be necessary for the stretch-wrap material width being used. Leave the unneeded spacer tubes on the material rod. Subtract from 20" the width of the material on the roll that will be used -- the difference is the total length of the rod spacer(s) you will need.
17. Place the material tube onto the material holder rod, lowering it over the bottom tube retainer. When the roll is correctly mounted onto the rod, the material should pull from the outer side of the roll when the material is pulled towards the turntable.
18. Place the top tube retainer into the top of the material tube, and then drop any needed rod spacer tubes onto the top of the top tube retainer.
19. Screw the material tension handle onto the top of the material rod. The tension handle should screw down onto the top of either the bearing in the top tube retainer or onto a spacer tube.

Longer film rods are available for 40" and 60" material. However, for material lengths over 20", it will be very difficult to move the mast up and down due to the counterweight being significantly less than the weight of the wrap.

ROUTINE MAINTENANCE & SAFETY CHECKS – SWA-48, POW-CAR

- o *Warning: Care should be taken to identify all potential hazards and comply with applicable safety procedures before beginning work.*
 - o *Only qualified individuals trained to understand mechanical devices and their associated electrical circuits should attempt troubleshooting and repair of this equipment.*
 - o *Note: Record the maximum turntable rotation speed when the machine is installed. This will allow a reference for evaluating drive belt slippage during future maintenance checks.*
- (A) Before each use inspect for the following:
- 1.) Frayed or damaged wires.
 - 2.) Damage or structural deformation to the stretch-wrap mast, the machine's frame, or the turntable.
 - 3.) Damage to any of the machine's control or power transmission components, particularly to the foot switch, its guard, or its cord.
 - 4.) Unusual noise or binding, or evidence thereof.
 - 5.) Smooth and proper movement of the stretch-wrap mast carriage.
- (B) Inspect monthly for:
- 1.) Worn or damaged electrical wires.
 - 2.) Damage to the motor speed control. If the speed control's enclosure has been broken, the drive should be replaced.
 - 3.) Looseness of the drive belt. See "Note," above. Slipping of the drive belt will cause it to wear out rapidly, and the turntable will rotate slower than intended or not at all. The belt tension is adjusted by the socket-head screws on the side of the gear reducer mounting bracket. See the "Belt Tensioning Procedure" on the following page.
 - 4.) Wear or impact damage to the edge of the turntable plate.
Warning: Sharp edges or burrs can develop at the edge of the turntable plate by a fork truck's forks scraping the top of the plate or by a fork impacting the edge of the plate during loading and unloading. To prevent potential injury to personnel, these must be filed, sanded or ground smooth.
 - 5.) Damaged or worn load bearings. This is indicated by a scraping sound from the turntable during operation and by grooves developing on the bottom side of the turntable.
 - 6.) Wear of the turntable's main bearing. Check that the turntable is parallel with the top of the machine's frame and that there is no wobble when the edge of the turntable is shaken.
 - 7.) Excessive wear to the mast carriage slides, or to the fiber washer under the stretch-wrap material .
 - 8.) The integrity of the frame anchors, and for cracks in the concrete around them.
 - 9.) Unusual noises or movement during operation.
 - 10.) All the information, safety, and warning labels being in place and in good condition.
 - 11.) The need to clean off dirt and debris, particularly anything that has built up underneath the turntable.

In the event of a sudden and severe shock load to the turntable's drive system, such as when the load is stopped instantaneously while spinning due to a fork truck backing too close to the load, damage could occur to the drive system components (belt, pulleys, torque limiter, gear reducer, motor). Such damage is not covered under warranty.

The gear reducer uses .

The disassembly of the gear reducer will void its warranty, and at the manufacturer's discretion may void all warranty of the stretch-wrap machine.

BELT TENSIONING PROCEDURE -- SWA-48, POW-CAR

Note: Once the belt is tensioned, the top of the motor should be tilted slightly toward the end of the machine's frame.

1.) Loosen the four bolts holding the gear reducer to its mounting bracket.

2.) If necessary to gain more adjustment, loosen the gear reducer bracket's mounting bolts and slide it nearer to the end of the machine's frame.

3.) Retighten the bolts holding the gear reducer onto its mounting bracket.

4.) Loosen the jam nuts and turn these screws CW to increase the belt tension. Then retighten the jam nuts against the mounting bracket.

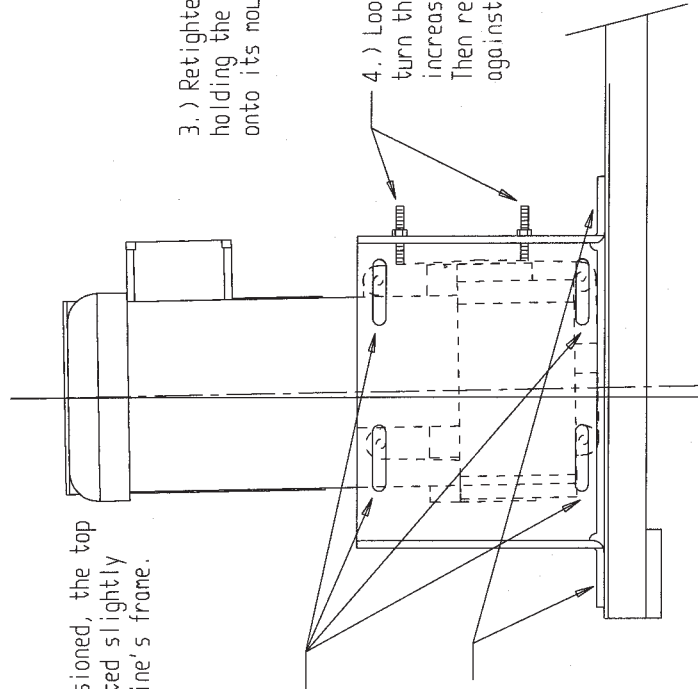

OPERATION INSTRUCTIONS – SWA-48, POW-CAR

*** *Ensure that all employees involved in the operation and care of this machine understand and follow these instructions!*

The standard model SWA-48 is suitable for moderate-duty, intermittent cycling with a 4,000 pound load. It is intended to be used indoors in industrial and commercial locations to apply stretch-wrap material at between three and twelve revolutions per minute (RPM) in a clockwise rotation around palletized, stable, non-hazardous loads. The maximum diameter (or diagonal, measured corner-to-corner) load size for the SWA-48 is 76", the maximum load height is 78". Always ensure that the load is centered on the turntable.

The material mast can utilize stretch-wrap material rolls in lengths from 10" to 20" — spacer tubes stored on the material rod allow for the use of several material roll lengths below 20". The SWA will generally be capable of achieving stretch-wrap material stretch rates of 150-200%.

Loading:

The load rating, in pounds, is shown on the machine dataplate located on the frame near the gear reducer mounting bracket. It indicates the net capacity of the turntable with a load that is centered and evenly distributed.

Note: The addition of any ancillary equipment to the turntable, such as a conveyor, must be taken into account when determining the maximum working load to be placed on the turntable.

Warning: Verify that no part of the load is overhanging below the turntable. A damaged skid with a dragging board or an overhanging load that sags below the turntable can cause the entire load to shift suddenly if it catches on the frame.

Caution: Do not exceed the machine's load ratings. Damage or premature failure to the drive system or its components could result from exceeding the listed capacity.

Place loads onto the turntable slowly and gently with a pallet truck or walk-behind fork lift (using an optional approach ramp), or with a fork truck.

Caution: Do not drop loads onto the turntable. Even a two-inch drop onto the turntable creates a shock load on the load bearings that will result in their premature failure.

See the installation page in this manual for instructions on how to install a roll of stretch-wrap material onto the mast carriage.

Operation:

Warning: Keep all personnel clear of the machine when it is in operation. Be certain no part of any person, fork truck, or other object is in the path of the rotating load before rotating the turntable.

Warning: Do not stand or sit on the turntable or its load at any time.

Warning: Keep all body parts and clothing away from the machine's drive system(s).

Caution: Do not use the stretch-wrap machine if any damage or unusual noise is observed, if it is in need of repairs, or if it seems to be malfunctioning. Notify your supervisor or maintenance personnel if you notice anything out of the ordinary.

The standard stretch-wrap machine is furnished with a constant-pressure (dead-man style) foot switch control. Pressing the foot switch will turn on the motor to rotate the turntable. The turntable will rotate only while the control is pressed. Upon releasing the control, the turntable will coast to a stop.

The turntable speed can be adjusted with the speed control knob on the front of the motor speed control. The display on the front of the motor controller shows the approximate RPM of the turntable. Turn the speed control knob clockwise to increase the turntable speed, and counterclockwise to decrease the speed.

Pull the handle upward to move the stretch-wrap material roll upward. Push the handle down to move the material downward. Control of the tension/stretch of the stretch-wrap material is achieved by turning the handle on top of the material. Screw the handle clockwise (downward) to increase the material tension and stretch, and turn it counterclockwise (upward) to decrease the material stretch.

Caution: Always carefully watch the palletized load when the turntable is rotating.

Set the material tensioner so the material will pull off the roll easily. Pull stretch-wrap material off the roll and either hold or tie it to the load to be wrapped. Press the foot switch to rotate the load.

After one or two overlaps, tension the material to the desired stretch rate. Raise and lower the material carriage until the load is covered 100%, with two or three overlaps. While the turntable is still rotating, the material can either be cut with a knife or torn with the hands. Press and smooth the cut end of the material up against the side of the load.

Note: The best wrapping results for palletized loads is generally achieved by having the wrap overlap the sides of the pallet at the bottom and extending slightly above the load at the top.

Ensure that all safety and warning labels stay in place and are legible. Refer to the labels page in this manual.

EXPLODED PARTS VIEW AND BILL OF MATERIALS — SWA-48, POW-CAR

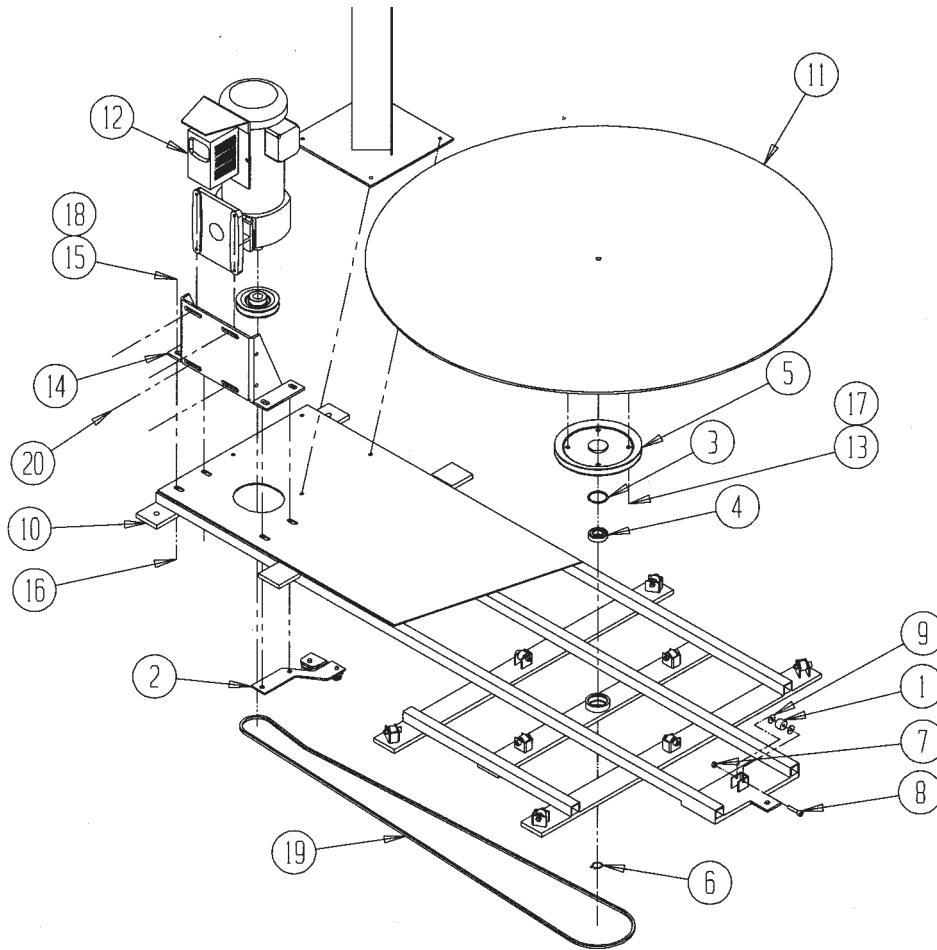

Item#	Part Number	Description	Quantity
1	20-110-003	Bearing, cam follower, 1" dia.	10
2	20-540-001	Assembly, lever / tension arm	1
3	20-117-001	Retaining ring, internal	1
4	20-110-001	Bearing, ball	1
5	20-542-006	Weldment, pulley / pin, driven, 9" OD	1
6	20-117-003	Retaining ring, external, 1"	1
7	a/l	Nut, nylock, 5/16" - 18 UNC	10
8	a/l	Bolt, 5/16 - 18 UNC x 2" Lg.	10
9	a/l	Washer, flat, 5/16" ID	10
10	20-514-006	Subassembly, frame	1
11	20-513-031	Weldment, deck, 48" dia x 1/4" checker plate	1
12	20-641-006	Assembly, control/motor/gear reducer/pulley	1
	20-135-003	Motor, 3-phase, 230V	1
	20-029-006	Control, inverter, 115V	1
	20-141-002	Reducer, gear	1
	20-042-019	Pulley, 4 7/16" OD	1
13	a/l	Screw, 3/8" - 16 UNC x 3/4" Lg.	4
14	20-016-032	Bracket, mount, motor	1
15	a/l	Screw, 3/8" - 16 UNC x 1" Lg.	4
16	a/l	Nut, 3/8" - 16 UNC	4
17	a/l	Washer, lock, 3/8"	8
18	a/l	Washer, flat, 3/8"	4
19	Consult factory	Belt, drive	1
20	a/l	Bolt, 3/8" - 16 UNC x 7/8" Lg.	4

Exploded Parts View — Stretch-Wrap Masts

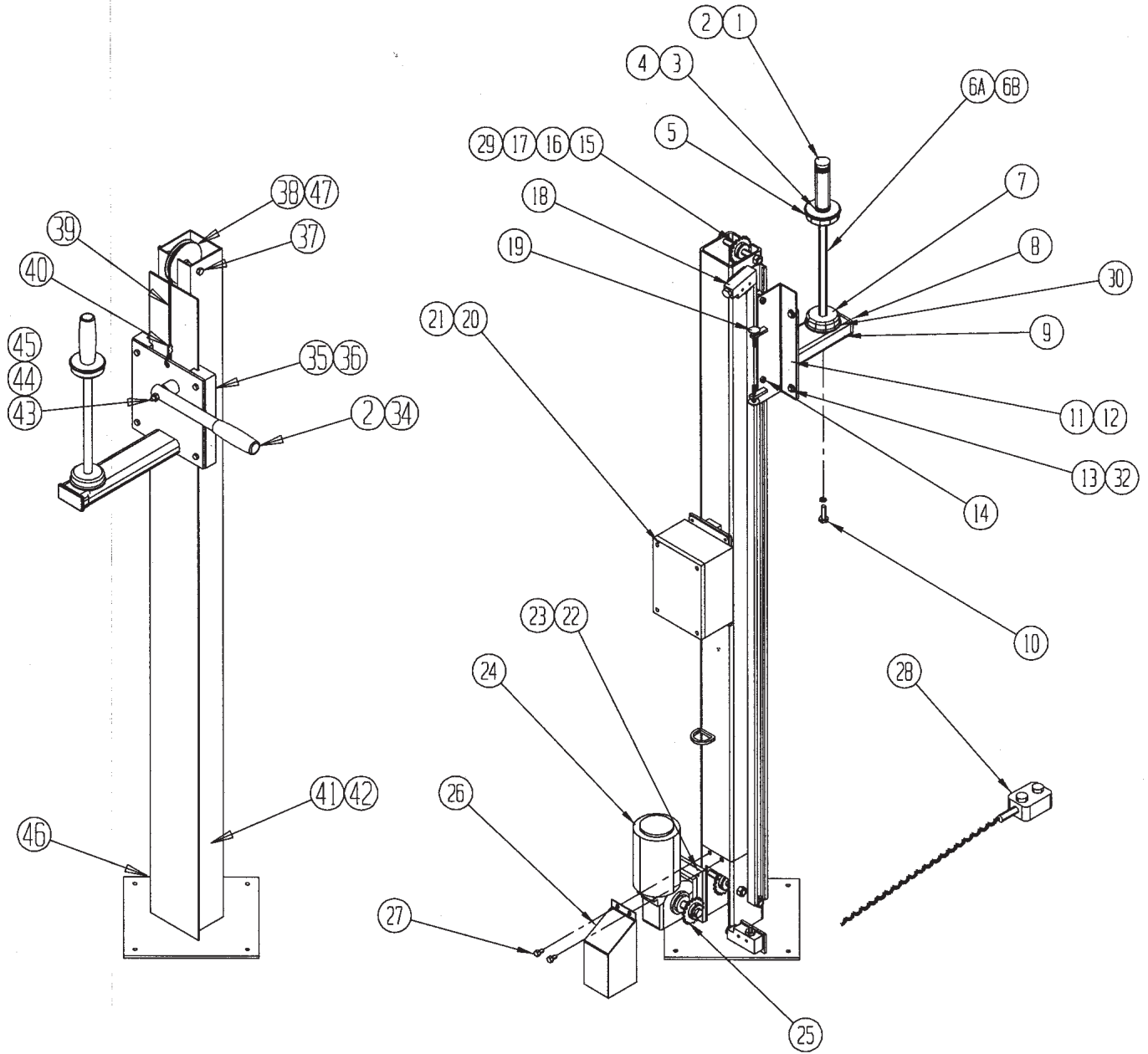

(31) NOT SHOWN FOR CLARITY

Bill of Materials — Stretch-wrap Masts (On All Models)

Item#	Part Number	Description	Used on	Quantity
1	20-025-001	Grip, handle, threaded	Both	1
2	13-025-003	Grip, handle, 1-1/8"ID (two used on the manual mast)	Both	1
3	20-117-002	Retaining ring	Both	1
4	20-110-002	Bearing, ball	Both	1
5	20-014-006	Tube retainer, top	Both	1
6A	20-026-002	Shaft, material, 25-1/2" Lg.	Both	1
6B	20-154-007	Kit, spacer, material rod (2", 3", & 5" tubes)	Both	1
7	20-014-005	Tube retainer, bottom	Both	1
8	20-024-003	Guard / cover, plastic	Both	1
9	20-516-004	Assembly carriage, material holder	Both	1
10	A/L	Washer, lock, and bolt, 3/8" - 16 UNC x 1-1/4"	Both	1
11	20-514-019	Weldment, slide, material holder	PMO	2
12	20-016-026	Bracket, roller, mast	PMO	2
13	A/L	Bolt, 5/16 - 18 UNC x 3/4" Lg.	PMO	4
14	20-110-008	Bearing, roller (w/ 5/16" - 18 UNC nylock nut)	PMO	4
15	20-042-008	Sprocket, idler	PMO	3
16	A/L	Bolt, 1/2" - 13 UNC x 4-1/2" Lg.	PMO	3
17	20-113-005	Spacer	PMO	6
18	01-022-021	Switch, limit, plunger	PMO	2
19	A/L	Bolt, elevator, 1/4" - 20 UNC x 1-1/2", w/ nut	PMO	2
20	01-029-007	Enclosure, control, 6" x 8" x 4" deep	PMO	1
21	A/L	Washers, nylock nuts & bolts, #10 - 24 UNC x 3/4" Lg.	PMO	4
22	A/L	Bolt & nylock nut, 1/4" - 20 UNC x 1" Lg.	PMO	2
23	A/L	Bolt & nylok nut, 1/4" - 20 UNC x 3/4" Lg.	PMO	2
24	20-141-003	Gearmotor	PMO	1
25	20-042-009	Sprocket, drive	PMO	1
26	20-524-001	Assembly, plate, guard	PMO	1
27	A/L	Screw, self-tapping, 5/16" - 3/4" Lg.	PMO	2
28	01-522-019	Control, hand held, 2-button with coil cord	PMO	1
29	A/L	Washer, nut &, 1/2" - 13 UNC	PMO	2
30	20-113-003	Spacer, fiber	Both	1
31	20-042-010	Chain, roller, #35	PMO	1
32	A/L	Washer, nut &, 5/16" - 18 UNC	PMO	4
33	01-033-015	Cord, power, 9' (with NEMA 5 - 15 plug)	PMO	1
34	20-037-003	Handle, slide, carriage, mast	Manual	1
35	20-514-008	Assembly, slide, carriage, mast	Manual	1
36	20-014-007	Rails, slide, carriage	Manual	2
37	A/L	Bolt with nylock, 3/8" - 16 UNC x 5" Lg.	Manual	1
38	20-027-001	Pulley, counterweight, 4" diameter	Manual	1
39	A/L	Cable, 1/8" dia x 76" Lg.	Manual	1
40	A/L	Crimp, cable	Manual	2
41	A/L	Link, chain, roller 3/16" dia.	Manual	2
42	20-017-007	Counterweight	Manual	1
43	20-118-001	Handle, brake release, carriage	Manual	1
44	A/L	Washer, spring, 3/4" x .06" thick	Manual	12
45	20-037-002	Disk, brake, carriage	Manual	1
46	20-514-005	Assembly, mast, complete	Manual	1

Electrical Diagrams -- SWA-48, POW-CAR

- *** *Warning: Care should be taken to identify all potential hazards and comply with applicable safety procedures before beginning work. Ensure that power have been removed before attempting to work on the electrical system.*
- *** *Only qualified individuals trained to understand mechanical devices and their associated electrical and hydraulic circuits should attempt troubleshooting and repair of this equipment.*

OVERCURRENT & SHORT-CIRCUIT PROTECTION ARE TO BE PROVIDED BY THE END-USER PER THE NEC (NFPA 70) AND LOCAL CODES.

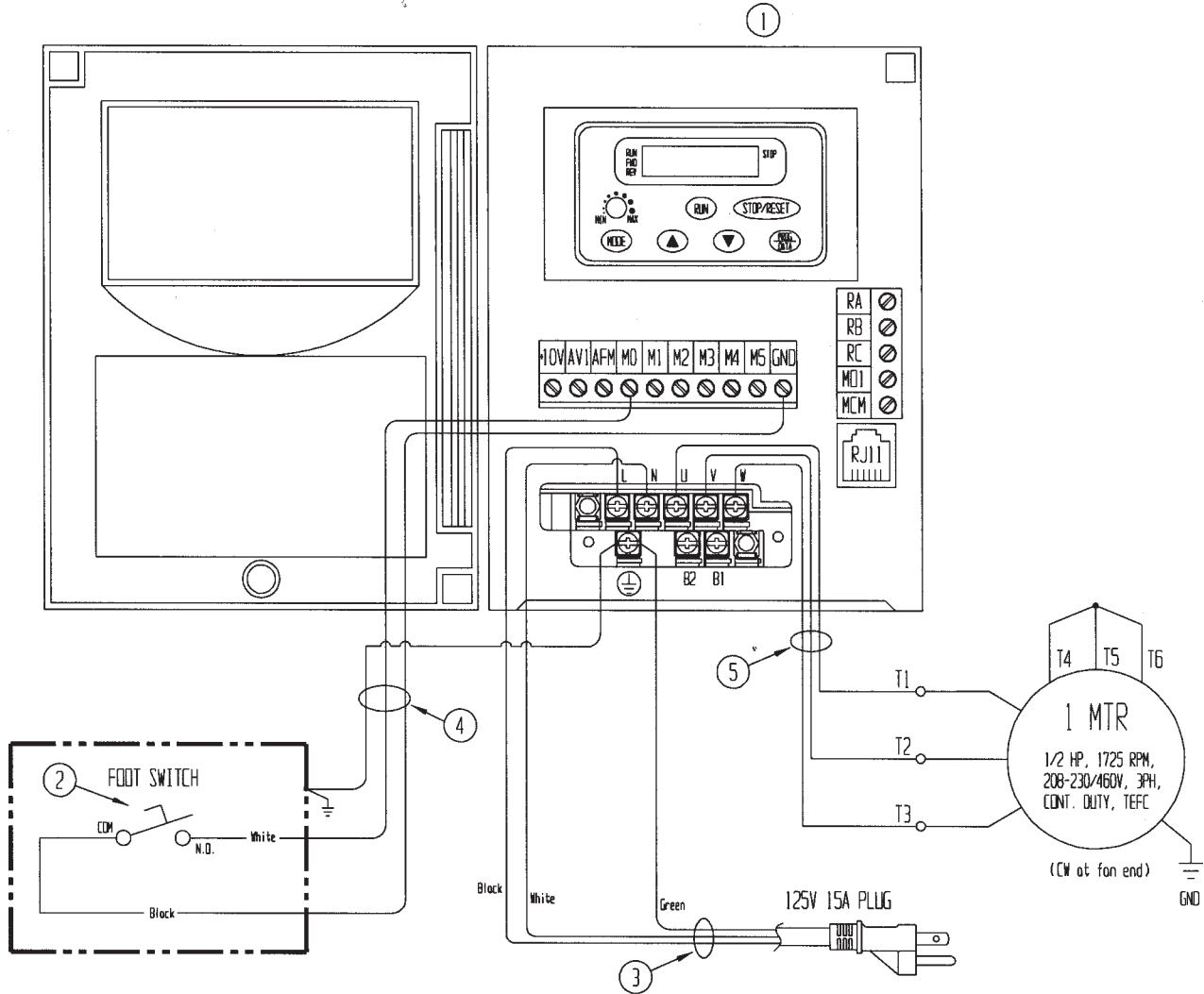

BE SURE ALL POWER IS OFF BEFORE ATTEMPTING TO WORK ON THIS EQUIPMENT!

CAUTION: SERVICE WORK SHOULD BE PERFORMED ONLY BY TRAINED & QUALIFIED PERSONNEL

Powered Mast

OVERCURRENT & SHORT-CIRCUIT PROTECTION ARE TO BE PROVIDED BY THE END-USER PER THE NEC (NFPA 70) AND LOCAL CODES.

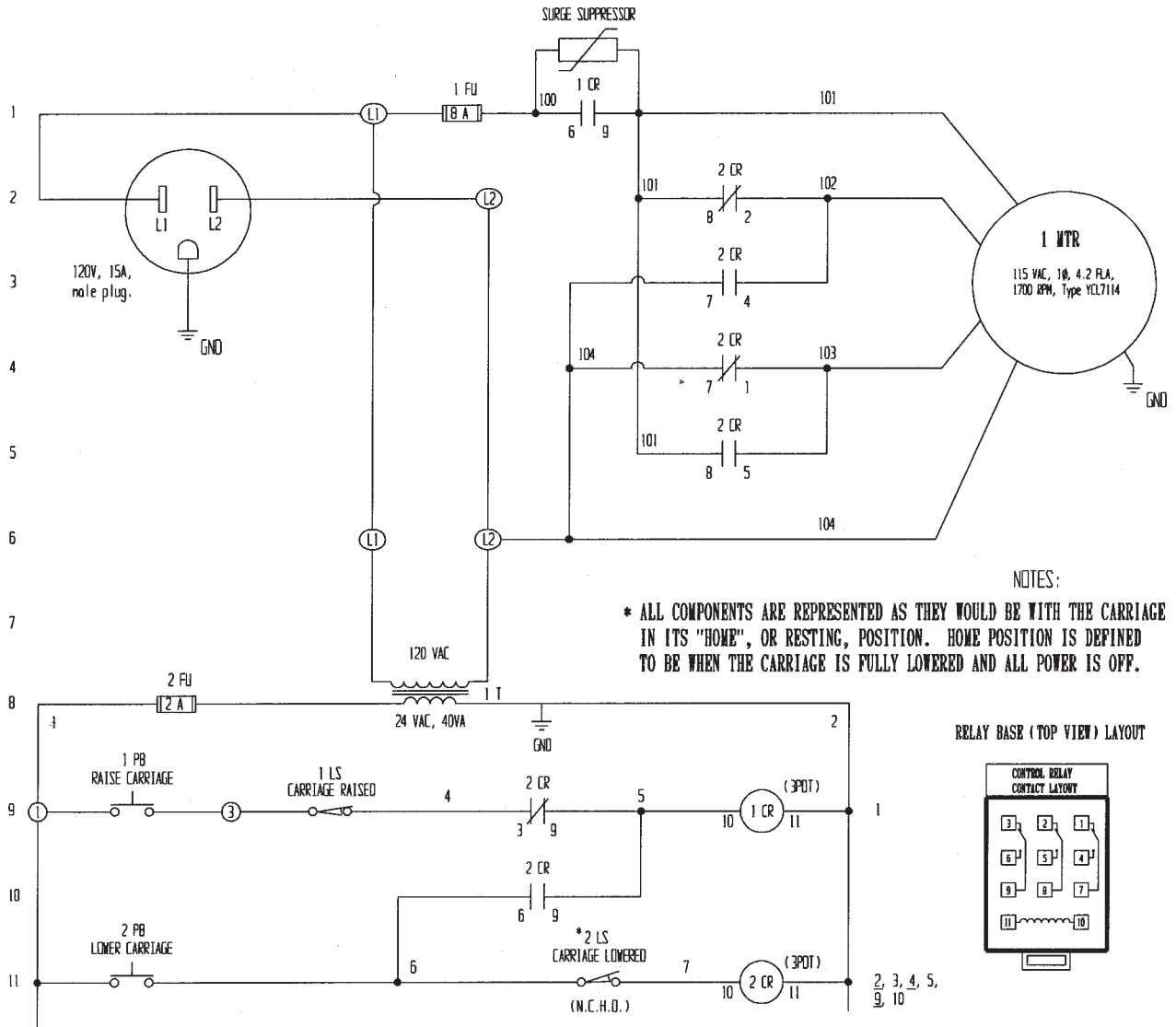

BE SURE ALL POWER IS OFF BEFORE ATTEMPTING TO WORK ON THIS EQUIPMENT!

CAUTION: SERVICE WORK SHOULD BE PERFORMED ONLY BY TRAINED & QUALIFIED PERSONNEL



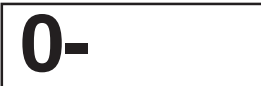

CHANGING DELTA MOTOR SPEED CONTROLLER PARAMETERS

1) Press to  switch to the program mode.

a) The following screen will appear:

 Indicating the specified parameter group.

b) Use the following keys to change all parameter settings in Step 2.

	Press "PROG/DATA" key to select parameter group and to store entered data. "END" displays for approx. 0.5 sec. if input has been accepted.
	Press "MODE" to scroll through all status at the drive; To show the turntable speed on the display, press "mode" three times after initial power-up. For example, when the turntable is rotating at 12 rpm, the display will appear as "u 12."
	Press "UP" or "DOWN" key to scroll through different parameters.
	Press "UP" or "DOWN" key momentarily will change parameter settings in single-unit increments.

2) Important drive parameter settings:

Parameter	Parameter Description	Setting	Setting Description
0-03	Start-Up Display Selection	d2	Display the content of user-defined unit.
0-05	User Defined Coefficient K	d0.3	Scales the frequency value so the display shows the approximate turntable rpm.
1-02	Maximum Output Voltage	d255	Sets the maximum voltage to the motor
1-07	Upper Bound of Freq.	d65	Sets the maximum rotation speed with the speed knob turned fully clockwise (about 11 rpm).
1-08	Lower Bound of Freq.	d15	Sets the minimum rotation speed with the speed knob turned fully counterclockwise (about 3 rpm).
1-09	Accel Time 1	d10 *	Time to accelerate the motor to the drive's maximum output frequency setpoint, in seconds.
1-15	Auto Accel / Decel	d0 *	Allows for a linear acceleration rate of the motor.
1-16	S-Curve in Acceleration	d7	Determines how smoothly the drive accelerates.
2-00	Source of Frequency Command	d 3	Allows the turntable speed to be controlled by the knob of the drive's keypad.
2-01	Source of Operation Command	d 1	Makes the drive turn on the external foot switch.
2-02	Stop Method	d 1	Allows the turntable to coast to a stop.
6-02	Over-Current Stall Prevention Level	d 150	Sets the maximum motor current, as a percentage of the drive's rated output.
6-03	Over-Torque Detection Mode	d3	Detection is enabled during Accel and continues until the Continuous Output Time Limit is reached.
6-04	Over-Torque Detection Level	d 200	Sets the maximum output torque, as a percentage of the drive's rated output.
6-05	Continuous Output Time Limit	d10	Determines the time the drive will run after over-torque is detected, in seconds.
7-00	Motor Rated Current	d 120	Affects the point at which the drive limits its output current, in percent of drive's rated output.
7-01	Motor No-load Current	d 75	Affects the drive's motor slip compensation.
7-02	Torque Compensation	d 10	Controls the motor's maximum start-up torque.

TROUBLESHOOTING GUIDE — SWA-48, POW-CAR

Warning: Before performing any task, always disconnect the power supply.

Consult the manufacturer for problems at time of installation, or for any problems not addressed below.

Problem	Possible Cause(s)	Action
<ul style="list-style-type: none"> • The turntable does not rotate. 	<ul style="list-style-type: none"> • No power supply voltage. • Speed control at its slowest setting • No control signal from the foot switch. • Motor controller fault, or defective motor controller. • Broken or slipping belt. 	<ul style="list-style-type: none"> • Check for 115V at the outlet into which the machine is connected. Find cause of power supply loss before resupplying power. (Note: if the turntable cord is plugged into the pigtail at the powered mast's enclosure, verify that the powered mast cord is plugged into an outlet.) • Increase the turntable speed at the knob on the front of the motor controller. • Check the foot switch and its cable for continuity. • Check the display on the controller for a fault code. Contact the factory. • If the fan on the drive motor is spinning, lift the mast end of the machine to inspect the belt. • See the last paragraph above.
<ul style="list-style-type: none"> • The turntable will not rotate without assistance, rotates slower when loaded, or will not achieve maximum speed. • The powered mast motor or control enclosure hums, chatters, or buzzes, and the film carriage does not move, or it moves only slowly. 	<ul style="list-style-type: none"> • See the last paragraph above. • Excess voltage drop to motor, due to power wire size too small, wire run too long, or incoming voltage too low. • Damage to the mast or carriage. • Low control voltage or bad connection in control circuit. 	<ul style="list-style-type: none"> • Check power supply for adequacy. Check incoming voltage while the motor is running. Correct by installing a circuit with larger wire, eliminating extension cords, or installing a buck/boost transformer. • Visually inspect the carriage and mast for signs of damage or excessive wear. • Verify 24 VAC at transformer secondary. Inspect all wires and connections in the mast control enclosure for looseness, etc. • See last paragraph above.
<ul style="list-style-type: none"> • The powered mast carriage will not raise or lower when either push-button is pressed. 	<ul style="list-style-type: none"> • See as last item above. • Transformer fuse is blown. • No power supply voltage. • Mast limit switch is engaged or bad. • Control relay 1 CR (left side in the enclosure) contact is burnt. • Control relay 1 CR has become loose. 	<ul style="list-style-type: none"> • Test with meter; replace if bad (Be sure to replace with the same fuse type and ampere value.) • See first item at the top of the page. • Inspect and test switch. Replace if bad. • Inspect contact. Clean contact or replace relay if burnt. Check for 115V at the motor relay. • Verify that the relay is firmly in place.
<ul style="list-style-type: none"> • Powered mast must carriage will raise but it will not lower. 	<ul style="list-style-type: none"> • Control relay 2 CR has become loose. • Control relay 2 CR is defective. • Bad connection in control circuit. • Physical blockage of the structure. 	<ul style="list-style-type: none"> • Inspect and test control relay 2 CR. Replace if bad. • Test all parts of circuit with meter. • Inspect for foreign material or objects that might block the carriage path.

SAFETY LABEL IDENTIFICATION

ONE YEAR LIMITED WA* Product safety signs or labels should be periodically inspected and cleaned by the product users as necessary to maintain good legibility for safe viewing distance – ANSI 535.4 (10.21). Contact the manufacturer for replacement labels.



2 x 2



221

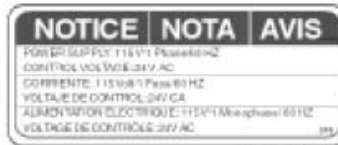

248 Style

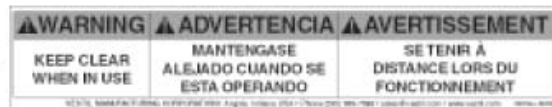

220



577

Both Sides



204



208



287

POWERED PRODUCTS' WARRANTY

ONE YEAR LIMITED WARRANTY

The manufacturer warrants for the original purchaser against defects in materials and workmanship under normal use one year after date of shipment (not to exceed 15 months after date of manufacture). Any part that is determined by the manufacturer to be defective in material or workmanship and returned to the manufacturer, shipping costs prepaid, will be, as the exclusive remedy, repaired or replaced at our option. Labor costs for warranty repairs and/or modifications are not covered unless done at manufacturer's facilities or pre-approved in advance by the manufacturer. Any modifications performed without written approval of the manufacturer may void warranty. This limited warranty gives purchaser specific legal rights which vary from state to state.

All specifications are subject to change without notice.

LIMITATION OF LIABILITY

To the extent allowable under applicable law, the manufacturer's liability for consequential and incidental damages is expressly disclaimed. The manufacturer's liability in any event is limited to, and shall not exceed, the purchase price paid. Misuse or modification may void warranty.

Warranty does not cover labor or consequential damages including, but not limited to, business interruption costs, lost profits, or lost business opportunities.

WARRANTY DISCLAIMER

The manufacturer has made a diligent effort to accurately illustrate and describe their products. However, such illustrations and descriptions are for the sole purpose of identification, and do not express or imply a warranty that the products are merchantable or fit for a particular purpose, or that the products will necessarily conform to the illustrations or descriptions.

The provisions of the warranty shall be construed and enforced in accordance with the Uniform Commercial Code and laws as enacted in the State of Indiana.

DISPOSITION

Our company will make a good faith effort for prompt correction or other adjustment with respect to any product that proves to be defective within the Limited Warranty Period. Warranty claims must be made in writing within said year.

Material Handling Problem Solvers

Scissor Lift Table

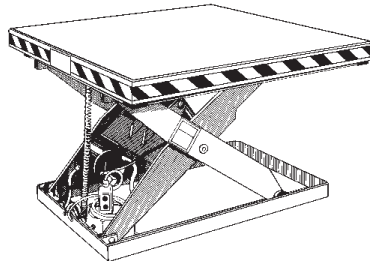

Pallet Server

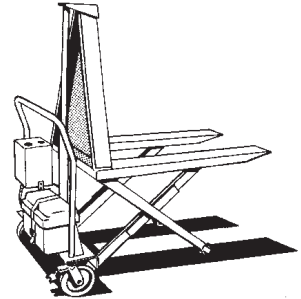
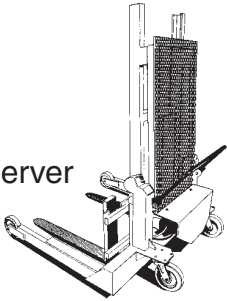

High Rise Lift

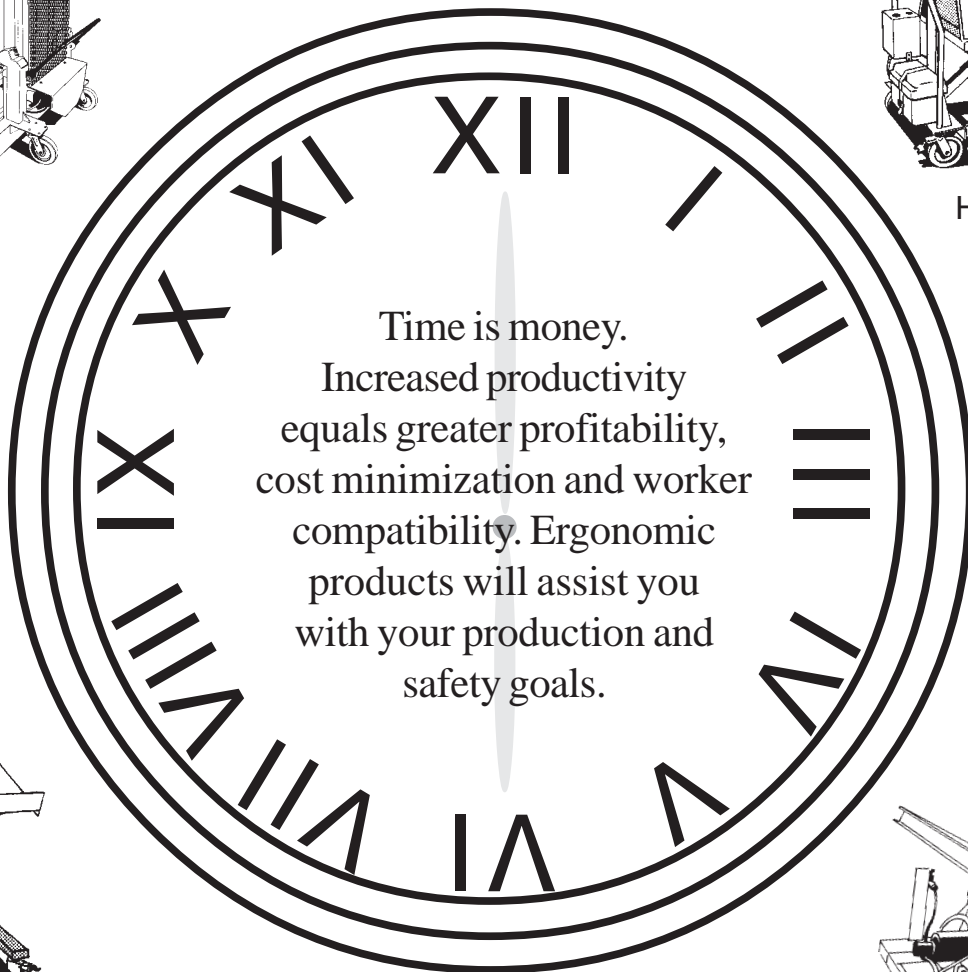

Time is money.
Increased productivity
equals greater profitability,
cost minimization and worker
compatibility. Ergonomic
products will assist you
with your production and
safety goals.

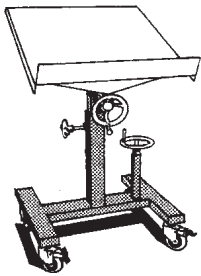

Mobile Lift & Tilt
Work Stand

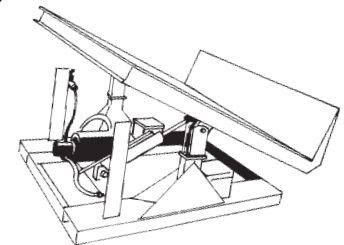

45° Container Tilter

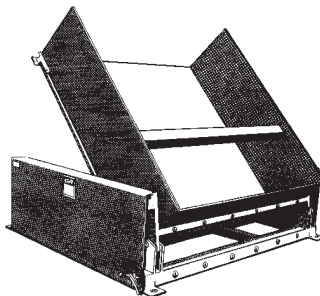

Ground Lift Tilter